

Head Treatment System



Head Treatment System - HTS

Boat owners constantly ask us how to eliminate TOILET SMELLS. One answer is to fit the correct type of hose: (see details of LEE-FLEX on separate leaflet). Having made sure that sewage smells cannot permeate your sanitation hose, it is appropriate to treat the incoming flushing water to destroy the Micro-growth which is another source of these bad smells.

Lee Sanitation provides two HTS treatment units each treating progressively serious growth. Both systems operate in a similar way but only the Adjustable HTS unit can be positioned below the waterline and closer to the seacock and therefore treat the problem nearer the source.

- COMBATS SMELLS
- COMBATS MICRO-GROWTH IN SYSTEM
- CLEANS BOWL & PLUMBING
- REDUCES MINERAL/SOLIDS BUILD-UP (SCALE)
- DEODOURISES AS IT CLEANS
- ENVIRONMENTALLY SAFE (NO FORMALDEHYDE)
- FAST AND SIMPLE TO FIT & REFILL
- KEEPS SYSTEM CLEAN & FRAGRANT

Note:

When toilet system has been unused for some time, the build-up of malodour causing micro-growth can be considerable. In this circumstance the HTS may not fully eliminate the problem. Use the HTS with "Water Flushing System" (see details on separate leaflet)

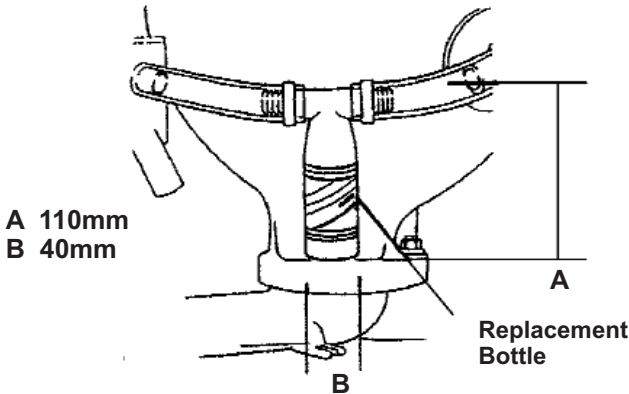

Part No: 07001

H.T.S. Standard

Effective on minor local problems, installed at bowl, treats single toilet. Must be mounted between the hand pump and toilet bowl

Spare Bottle Part No: 07002 (Single bottle)
07002.4 (Pack of 4 bottles)

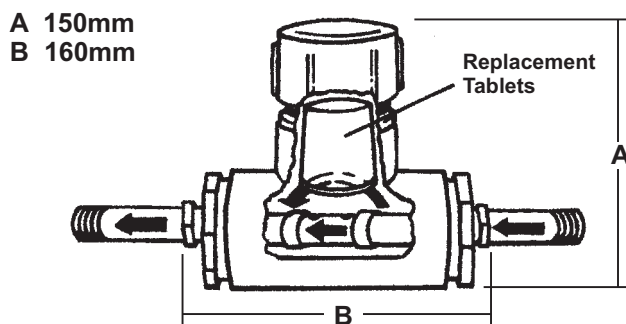

Part No: 01530

HT.S. Adjustable

Larger unit for coping with persistent problems, can be plumbed anywhere in inlet pipework. Volume of treatment can be adjusted to suit varying circumstances.

Spare Tablets Part No: 01529 (2 x Tablets)
01529.4 (Pack of 8 Tablets)

HTS Installation Positions

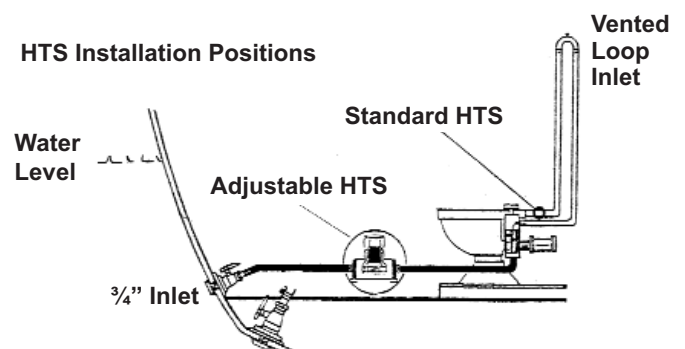

Head Treatment System Installation Guidelines

LeeSan Safety Advice!

Always close seacocks when leaving your boat unattended!

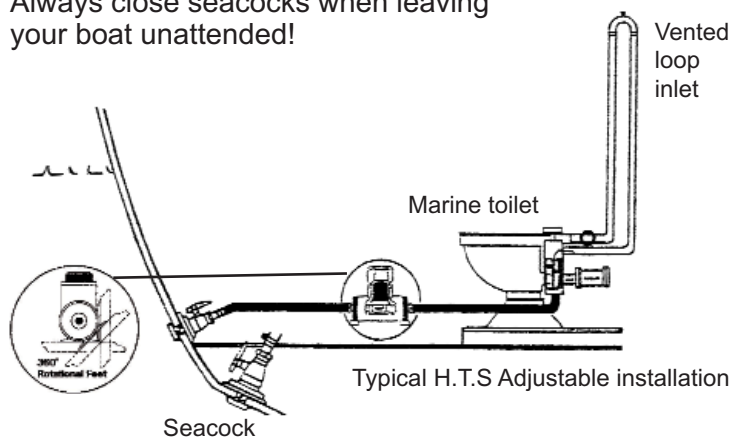

1. Identify the plumbing to the toilet pump and follow it to the seacock.
2. Close the seacock.
3. Select an "easy access" location where the H.T.S. can be mounted on any surface, adjusting the rotating feet to suit the angle keeping the H.T.S. upright. This enables easy replacement of the tablet. Installation can be anywhere in the pump inlet hose. The nearer the unit is fitted to the seacock the better (but not closer than 300mm). If using the hose tails supplied, fit into the H.T.S. with silicon seal around the threads. Do not use PTFE tape - Threaded pipe connections must be 1/2" N.P.T.
4. (Is the seacock closed?) At the chosen installation location, cut the inlet hose.
5. If necessary, apply a small amount of liquid soap to the H.T.S. hose tails, this will allow the hoses to slide more easily.
6. Slide the hose ends all the way up the hose tails and double clamp each end with stainless steel hose clamps.
7. Remove the H.T.S. cap (anticlockwise) and insert a treatment tablet
8. Replace the cap "finger tight" plus a 6mm turn (clockwise).

9. Open the seacock and pump the toilet pump until water appears in the bowl. Check for leaks around cap, 'O' ring and hose clamps: It will take approximately 1/2 to 1 hour before attaining results from the H.T.S.

10. The amount of inlet water treatment is adjustable by way of bushings, over the inlet pipe. (This pipe and bushings are under the tablet) These partly cover the inlet/outlet holes and slide to alter the amount of through flow.

Use a screwdriver to slide the bushings. Open holes to increase treatment. Close holes to smaller opening to reduce treatment or if tablet is dissolved too quickly.

The unit is factory set with both holes 'half' closed.

To replace the H.T.S. Tablet

1. Close the inlet seacock. Remove the cap from H.T.S. (anticlockwise) and pump the toilet slowly. This removes excess liquid from the cylinder of the treatment device.
2. Insert the new H.T.S. tablet Replace the cap "finger tight" plus a 6mm turn (clockwise).
3. Open the inlet seacock, pump the toilet and enjoy an odour free toilet system.

Suggested tools and parts needed for installation:

Knife, screwdriver, 4 x SS hose clips to suit.

NOTE:

H.T.S. is not recommended for use with pressurised systems drawing from the on board fresh water tank. Using anything but the H.T.S. toilet treatment tablet in the device may cause damage.