

MICROFLUSH® Half Gallon Toilets Air Operated



Model LF-210

Model LF-219

Installation/Service Manual

P/N 24563



452 East Hill Road, Willits, CA 95490 USA
Tel: 707.459.5563 • Tel: 800.358.8280 • Fax: 707.459.6617
www.microphor.com • www.wabtec.com

THANK YOU FOR PURCHASING A MICROPHOR PRODUCT!

Your Microflush® toilet is designed to provide you with years of reliable service while using only two quarts of water per flush. Please read this Owner's Manual completely prior to installation of your Microflush toilet. This will familiarize you with all of the proper installation and operation requirements.

CUSTOMER SERVICE

Please contact your local Microphor dealer for parts and service. For a list of dealers, please contact Microphor at 1-800-358-8280 or visit our website at www.microphor.com.

AIR SYSTEM

Filter-regulators are available in a variety of sizes and types. Their purpose is to remove water, oil and other foreign matter from the air line and to maintain a constant pressure **at the toilet of 60-65 PSI**. The following steps must be observed to assure moisture will be removed from the airline:

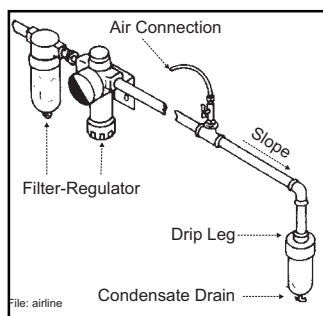

1. Drain air compressor receiver regularly. Most water tends to accumulate at this point.
2. Install drip legs with condensate drains at all low points in air piping.
3. Whenever possible, grade all airlines back to the air receiver or drip leg assembly and drain regularly.
4. The air supply to your Microflush toilet must be taken from the top of the main or branch air line.

AIR COMPRESSOR

Be certain compressor crankcase has proper oil levels. Locate the compressor in a clean, dry, well ventilated location. Size compressor according to separate Air Compressor Specifications Sheet.

PRE-INSTALLATION

The following procedures apply to all Microflush models unless otherwise noted. Remove your toilet from box carefully. Integral Models - Install toilet seat and flush handle before mounting Microflush to floor. Seat is not included. Bolt caps and closet screws are provided.

1. AIR LINES

If used in Marine applications, all piping supplied by customer is to conform to U.S.C.G. requirements relating

to water tight decks and bulkhead (46CFR56.69)

Be sure airline from compressor is of sufficient size, based on length of pipe run to head. We suggest 3/8" air line up to 40', 1/2" air line up to 75', and 3/4" air line for over 75'.

Install a filter-regulator assembly in incoming airline. Place the filter-regulator as close as possible to the first Microflush toilet and in an accessible location.

Set filter-regulator so that **60-65 PSI constant is available at the toilet**. Install Microphor combination filter/regulator/dryer, P/N 94036.

Assemble the Air Connecting Kit provided and connect to incoming air line with shut-off valve between bulkhead and toilet. For LF-210 Models, use Air Connecting Kit P/N 93086, and for LF-219 Integral Models use Air Connecting Kit P/N 95172. The plastic airline provided goes from the air supply to the Flush Activator. On integral models, the plastic air line enters the Microflush through the back wall or up through the floor under the unit. Make sure air is OFF at air compressor. **DO NOT CONNECT TO FLUSH ACTIVATOR YET!**

2. WATER LINES

Use a 1/2" water line and install a water shut-off valve (angle stop) between bulkhead and toilet. Water **at the toilet** must be regulated at an even pressure between **20 to 50 PSI** for Microflush to operate properly. Optimum pressure is 35 PSI. **DO NOT CONNECT WATER LINE TO MICROFLUSH YET!**

INSTALLATION PROCEDURES

3. DRAIN CONNECTION - See Rough-In Dimensions

FOR ALL INSTALLATIONS:

LF-210 Downward Discharge Model: Rest Microflush on its back on a padded surface (e.g. shipping box). Center wax ring over Hopper Flange. Turn Microflush toilet over, lift up, and center it with the horn of the wax ring into standard floor flange. Compress the wax ring by applying weight to your Microflush toilet. A second standard wax ring may be added if floor is uneven. If Hopper Flange hits floor flange, grind it down for added clearance, as any contact will break seal between Hopper and Toilet Bowl and cause leaking.

Note: Discharge on toilet is 13.25 (+/- 0.5") from back. See rough in dimensions.

All Rear Discharge Models: Install inverted P-Trap supplied with Microflush toilet. Do not glue or connect fittings until fitting alignment has been checked.

Caution: Outlet is 3/4" off centerline. Make sure toilet discharge and waste line are in line, not off set.

LF-219 Model: For downward discharge, use molded P-Trap hose supplied. For rear discharge, use inverted P-Trap. See page 8 for part numbers.

Remote Models: Position and mount the Remote Valve Assembly making sure the Vacuum Breaker is at least 6" above the rim of the Microflush toilet bowl. Measure air and water lines to make sure Remote Valve is mounted within connection distance to Microflush toilet. Run water and the three air lines from the Remote Valve Assembly to Microflush.

Caution: For Remote Flush Activators, make sure inside wall thickness does not exceed 1/2" or large mounting nut will restrict movement of flush handle.

Mount toilet bowl to floor with 1/4" closet bolts provided. Screw on bolt caps to mounting screws.

When using a 1-1/2" (38.1 mm) discharge line, each toilet must go individually to the Marine Sanitation Device or holding tank. Do not connect more than one toilet to a 1-1/2" (38.1 mm) discharge line.

If a vertical rise is required, the vertical rise must be at the toilet. The maximum vertical rise is 36". Vertical rise is not recommended for high use applications. The maximum horizontal run is 30 feet (9.14 meters) and must slope a minimum of 1/8" per foot (1 in 100) towards the Marine Sanitation Device or holding tank. For 1-1/2" lines, reduce horizontal pipe run 2 feet (.68 meters) per 90° elbow. Use long sweep elbows.

Note: The use of regular 90° elbows will significantly decrease the horizontal run.

When multiple toilets are installed, a vented 3" gravity collection line is to be used with not more than 4 toilets per 3" line. Manifold the 1-1/2" lines into the 3" collection line and provide a grade of at least 1/4" per foot towards the Marine Sanitation Device or holding tank. Vent 3" line at the manifold point.

Caution: Do not apply stress to align Microflush rear or downward discharge outlet to waste line. This may result in eventual damage to seal between Hopper and Toilet Bowl and cause leaking.

FOR MARINE INSTALLATIONS:

For direct overboard discharge, contact Microphor or your dealer.

4. WATER CONNECTION

Never install a check valve on the inlet side of the Microflush toilet.

Integral Models - Connect incoming water from angle stop to water connector. Make sure WATER IS OFF at angle stop.

LF-210 Models - Water supply connector is made of nylon-plastic; be careful not to cross threads.

LF-219 Models - If integral model is connected to a potable water source, the unit requires installer to provide a Back Flow/Cross Contamination Prevention device. Please check applicable jurisdiction for requirements before installation.

Remote Models - Connect incoming water from angle stop to Microflush Hose Barb on the Remote Valve Assembly. Connect the water line from Remote Valve Assembly to the Flush Rim Spud Assembly. Make sure WATER IS OFF at angle stop.

START UP

1. Turn ON air supply at compressor.
2. Turn air ON at air shut-off cock (near but not connected to Flush Activator) to blow out airlines for a few seconds. This procedure should remove any debris or contaminants from the airline. Turn air OFF at shut-off valve.
3. Connect airline to Flush Activator. Make sure air shut-off valve is installed next to Flush Activator. Do not over-tighten fittings.
4. Turn ON air shut-off cock. Check total installation for air leaks using soapy water.
5. Turn ON water. Check for water leaks.
6. Flush your Microflush toilet four times, waiting twenty seconds between flushes to get water through system and operating regularly. To flush properly, hold down Flush Activator Handle or Button until flapper opens.

DOUBLE CHECK

1. Air pressure at Microflush toilet is at least 60-65 PSI.
2. Water Pressure at Microflush toilet is between 20-50 PSI, 35 PSI optimal.
3. Water level in bowl should be at top edge of flapper opening.
4. If your Microflush does not operate correctly, refer to troubleshooting sections.

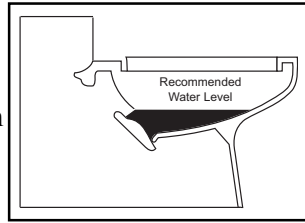

FLUSH CYCLE ACTIVATORS

There are two types of Flush Activators:

Standard - hold handle or button down for 1 second.

Positive - barely push handle or button to activate.

CLEANING BLEED-OFF PLUG ASSEMBLY

Standard Flush:

Remove plug and clean with solvent; air blow dry.

Positive Flush:

Remove plug and clean with solvent; air blow dry; remove and clean plug on Detent Valve.

Note: Use 5/32" or 4mm Allen wrench to remove plugs.

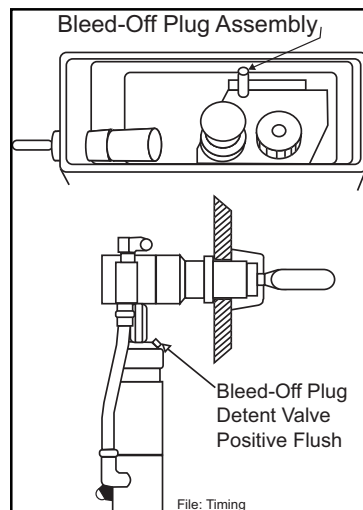

Note: Bleed-Off plugs on Air & Water Sequence Valves and Detent Valves are different sizes that are not interchangeable.

MAINTENANCE/CLEANING/CLEARING/WINTERIZING

ROUTINE MAINTENANCE

Your Microflush toilet has an air-operated Air/Water Sequence Valve which requires periodic lubrication with a silicone based lubricant.

USAGE	LUBRICATE
Light	Every 5 years
Medium	Every 2-3 years
Heavy	Every year

Check your application at right to determine how often to lubricate your Air/Water Sequence Valve. The Air Cylinder should be serviced if you have to take up your Microflush toilet for any reason. **The air system must be free of moisture. Drain air receiver regularly to remove moisture.**

CLEANING

Use Micro-Clean Organic Spray Cleaner, P/N 24542.

Sanitizers like Lysol, Pine-Sol, Hexol, ammonia base products, caustic drain openers or non-biodegradable cleaners should never be used if the plumbing system is connected to a Microphor Marine Sanitation Device.

1. While depressing the Flush Activator, turn OFF the water. Allow the bowl cleaner to flow into the lower chamber. Keep the Flushing Activator depressed.
2. Insert bowl brush into lower chamber and agitate mixture carefully. Remove the bowl brush and release the flush activator.
3. Turn the water ON and flush twice to rinse thoroughly.

Use MicroScrub, P/N 24827, to clean the hopper.

1. Turn off water and depress flush activator.
2. Dispense 1/2 bottle of MicroScrub into the hopper.
3. Turn on water and allow MicroScrub to stay in the hopper as long as possible before flushing.

CLEARING YOUR MICROFLUSH TOILET

If your Microflush toilet becomes plugged, shut off the water supply, press the flush handle and hold. The flapper will remain open until flush handle is released. Check to see if the restriction can be removed from lower portion of Microflush toilet with a hooked wire, being careful not to damage the rubber seal on the flapper or the mating surface on the hopper. If obstruction cannot be picked out with a hook or tongs, use plunger by pushing in slowly and pulling out quickly to pull object back into the hopper. If necessary, turn air off and use a snake inserted through a short plastic pipe placed in hopper. Pipe will protect flapper seal. If valve will not operate with water off, hold flush lever down and turn water on and off quickly to free valve action. When the

passage becomes clear, turn on water and press flush handle to start flush cycle.

WINTERIZING (Out-of-Service Winter Storage)

Shut OFF water to Microflush toilet. Flush Microflush toilet three times or until water no longer flows into the bowl. Unhook water supply at angle stop. Empty water in line into receptacle. Shut OFF air supply to your Microflush toilet. The unit is now prepared for freezing temperatures. OPEN petcocks on drip legs and air receiver drain after shutting down air compressor and isolating airlines.

WARNINGS

- *Do not use any petroleum based lubricants (Vaseline) on any rubber parts or o-rings as damage will occur. Use only silicone based lubricants.*
- *Do not use any 'Loctite' brand adhesives on any plastic or Delrin components as fumes will cause damage.*
- *Do not use Teflon tape on any air fittings as clogging may occur.*

PATENTS

Microflush® Toilets are covered by one or more of the following U.S. patents: 5245710; 4918764; 1280554; 169471 and related foreign patents.

DESIGN CHANGES

Continuing a policy of research and development, Microphor reserves the right of price, product or design change without notice or obligation.

TROUBLESHOOTING

Your Microflush® toilet is designed to give you years of trouble-free operation. Please check the following before beginning any service or repair:

Water supply:

1. Is the water turned on?
2. Is the water pressure between 20 and 50 PSI at the toilet for pressure water system?

Fluctuating or high water pressure can cause intermittent problems with the toilet operation. Check the water pressure at different times of the day (i.e., early morning, noon, evening) to determine if you have fluctuating or high water pressure. A pressure-reducing valve installed on the incoming water line will assure you have even pressure. Make sure no check valve is installed before the Air/Water Sequence Valve.

*Note: Water seal of flapper does not require complete submersion as flapper seal gasket provides complete hopper seal.

Air system:

1. Is the air turned on?
2. Is the air pressure set at a constant 60-65 PSI at the toilet?
3. Do you have any air leaks or kinks in the air system?
4. Do you have water in the air system? This usually causes irregular timing.

Drain the compressor tank and check the filter regulator and drip leg(s) for water. To check for water in Air/Water Sequence Valve, remove Bleed Off Plug, put finger over screw opening and flush. If water is present, it will squirt from sides of valve body. If water is detected, then the air cylinder and airlines must also be drained.

Cycle time:

1. Is the flapper cycle time set correctly at 4-7 seconds?
2. Is the bleed off plug blocked? Remove, clean and reinstall or replace.

Trouble	Possible Causes	Correction
Flapper does not open. Water does not flow. Nothing happens.	<ol style="list-style-type: none"> 1. No air supply to toilet 2. Water has accumulated in Air/Water Sequence Valve 	<ol style="list-style-type: none"> 1. Supply compressed air at 60-65 PSI at the toilet 2. See "Check Air System" above
Flapper opens and closes 4-7 seconds after handle is released, but no water enters bowl	<ol style="list-style-type: none"> 1. No water supply to toilet 2. Water turned off 	<ol style="list-style-type: none"> 1. Supply water at 20-50 PSI 2. Open angle stop (shut-off valve)
Flapper opens when flushed, and closes immediately when activator is released	<ol style="list-style-type: none"> 1. Excessively high water pressure 2. Debris in check valve at base of Air/Water Sequence Valve 	<ol style="list-style-type: none"> 1. Install water pressure regulating valve, set at 20-50 PSI 2. Clean Air/Water Sequence Valve
Flapper opens and will not close	Bleed Off plug blocked	Remove, clean or replace, reinstall
Water continues to run when toilet is not in use	Foreign object is under water seal in Air/Water Sequence Valve	Clean, replace or rebuild Air/Water Sequence Valve
Water splashes when flushed	Water is too high in bowl	Reduce incoming water via angle stop (shut-off valve)
Flush cycle is too long	Bleed-Off Plug blocked	Remove, clean or replace, reinstall
Flush cycle is too short	Air line leakage	Check for air leakage at all connections

If other problems are encountered, please contact Microphor toll-free at 1-800-358-8280.

EXPLODED VIEWS

- A Toilet Shell
- B Toilet Lid
- C Closet Screws
- D Flush Activator
- E Air/Water Seq. Valve
- F Vacuum Breaker
- G Bleed Off Plug
- H Valve Bracket
- I Hopper Assembly
- J P-Trap, Rear Discharge
- K Hopper Bleed Valve
- L Hopper Screws
- M Air Cylinder
- N Flapper Assembly
- O Crank Assembly
- P Water Supply Tube
- Q Water Connection
- R Hopper Gasket
- S Air Supply Kit
- T Pressure Relief Valve

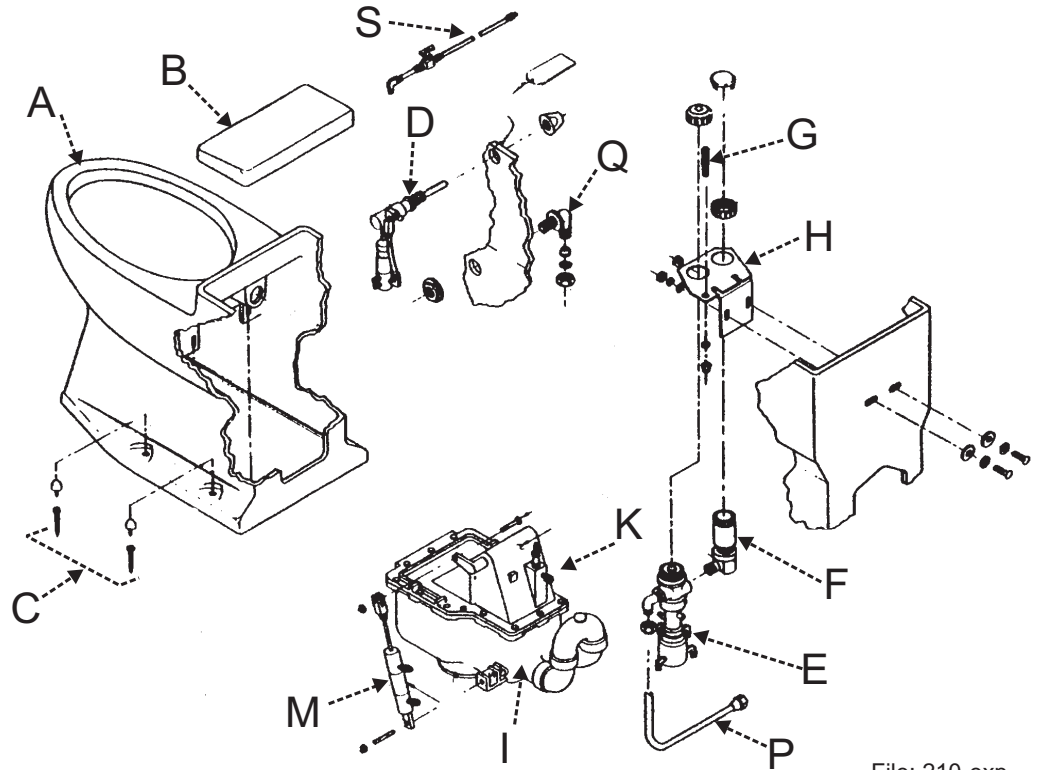

File: 210-exp

Typical Remote Assembly

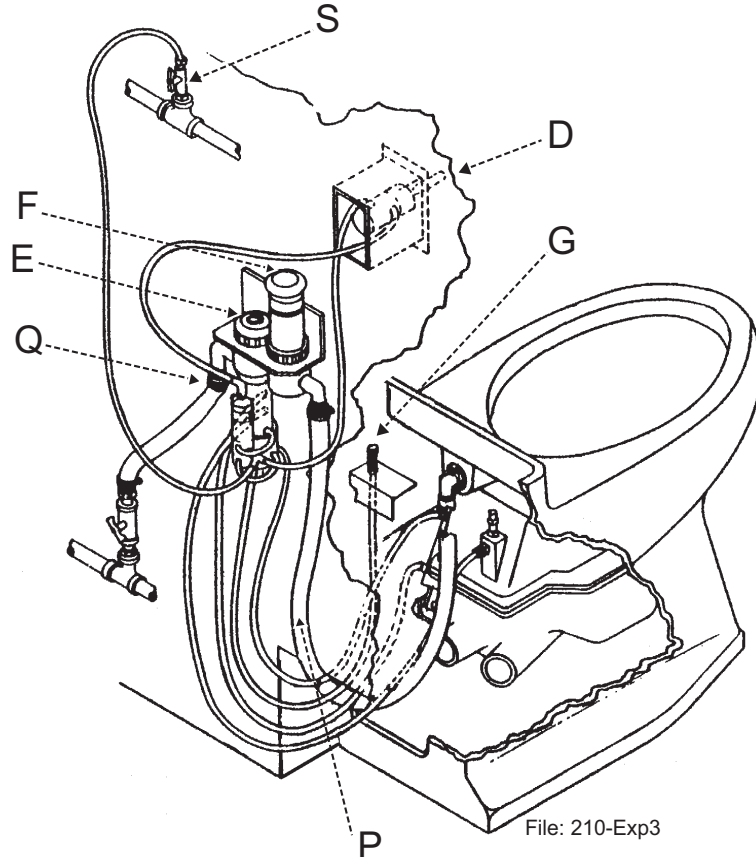

File: 210-Exp3

Rear Discharge Hopper

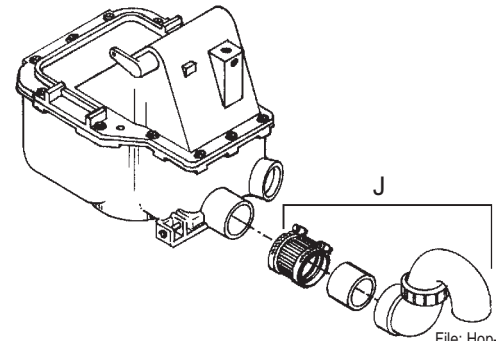

File: Hop-2

Downward Discharge Hopper

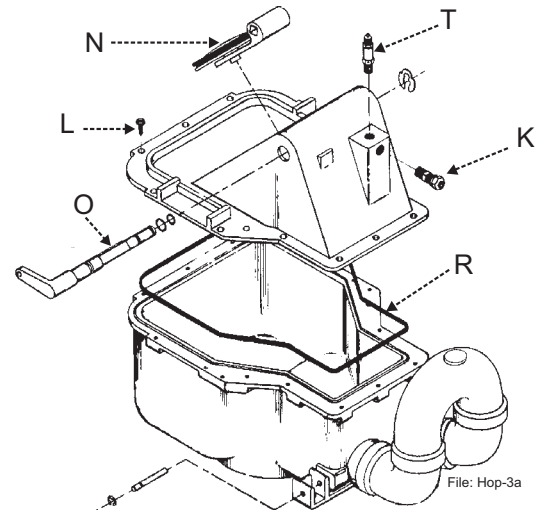

File: Hop-3a

PARTS CHART

		LF-210 Round	LF-210 Elongated	LF-219 Round	
				Integral	Remote
A	Toilet Shell White Biscuit Black Gray	93734	93732	93682	93683
		93734-3	93732-3	93682-3	93683-3
		93734-5	93732-5	93682-5	93683-5
		93734-7	93732-7	93682-7	93683-7
B	Toilet Lid White Biscuit Black Gray	94537		Not Applicable	
		94537-3			
		94537-5			
		94537-7			
C	Closet Screws & Bolt Caps White Biscuit Black Gray	93972			
		44370			
		44369			
		44377			
D	Flush Activator	95002-Standard		95183-3 White	95152
		95054-Positive		95183-5 Biscuit	
				95183-7 Black	
				95183-11 Gray	
E	Air/Water Sequence Valve	39014			
F	Vacuum Breaker	39034		33421	39034
				Check valve	
G	Bleed-Off Assembly	94598			
H	Valve Bracket	94533		20137	20003
I	Hopper	90067-Rear Discharge		90057-Rear	90067-Rear
		90065-Down Discharge		90077-Down	90065-Down
J	P-Trap, Rear Discharge	96029-Rear 90008-Bottom			
K	Hopper Bleed Valve	37548			
L	Hopper Screws	00064 (14 ea.)			
M	Air Cylinder	94540			
N	Flapper Assembly	90048			
O	Crank Assembly	90042			
P	Water Supply Tube	96012		96012-7	39033
Q	Water Connection	96387		N/A	
R	Hopper Gasket	27272			
S	Air Supply Kit	93086			
T	Pressure Relief Valve	37518			

AIRLINE CONNECTIONS - SERVICE KITS - AIR/WATER SEQUENCE VALVE COMPONENTS

AIRLINE CONNECTIONS

From Air/Water Sequence Valve	To	Part Number
Red	Air Cylinder, bottom fitting	35383
White	Air Cylinder, top fitting	35385
Black	Bleed Off Plug	35419
Green	Flush Activator, front fitting	35381
Blue	Flush Activator, back fitting	35382
Yellow	Hopper	35384

SERVICE KITS

Description	Part Number
Master Service Kit	93100
Air/Water Sequence Valve	95187
Air Cylinder	94502
Flush Activator Pilot Valve (standard)	95020
Vacuum Breaker	95037
Positive Flush (Detent) Valve	95081
Flapper Replacement Kit	90066

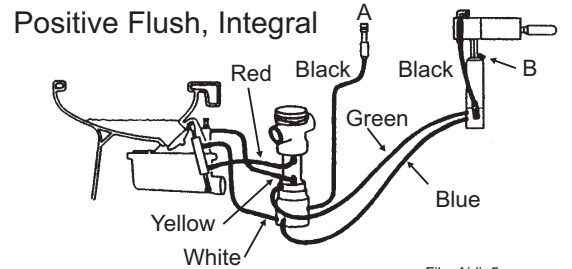
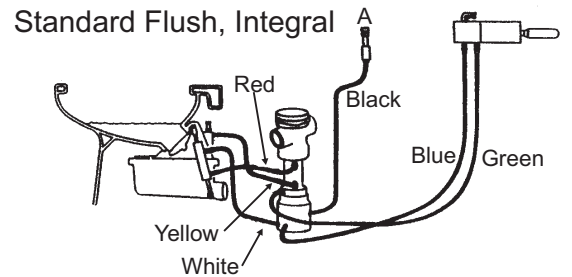

File: Airlin5

AIR/WATER SEQUENCE VALVE COMPONENTS

	Part Number	Description
1	39389	Water Body, A/W Sequence Valve
2	39388	Body, Main Valve
3	39096	Cap, Machined Bottom
4	39099	Insert, Top
5	27214	O-Ring, 2-023
6	95173-3	Insert Assembly
7	39394	Main Spool
8	27242	O-Ring, 2-039
9	39061	Main Spool Separator
10	27250	O-Ring, 2-113
11	39062	Secondary Spool Separator
12	10888	Spring, SS
13	39510	Blind Cylinder Piston
14	39097	Thread Cap Nut
15	39088	Check Valve Nut
16	10886	Spring, Bronze
17	39087	Check Valve System
18	27251	O-Ring, 2-008
19	27253	O-Ring, 2-217
20	27244	O-Ring, 2-130
21	26013	Lubricant, O-Ring

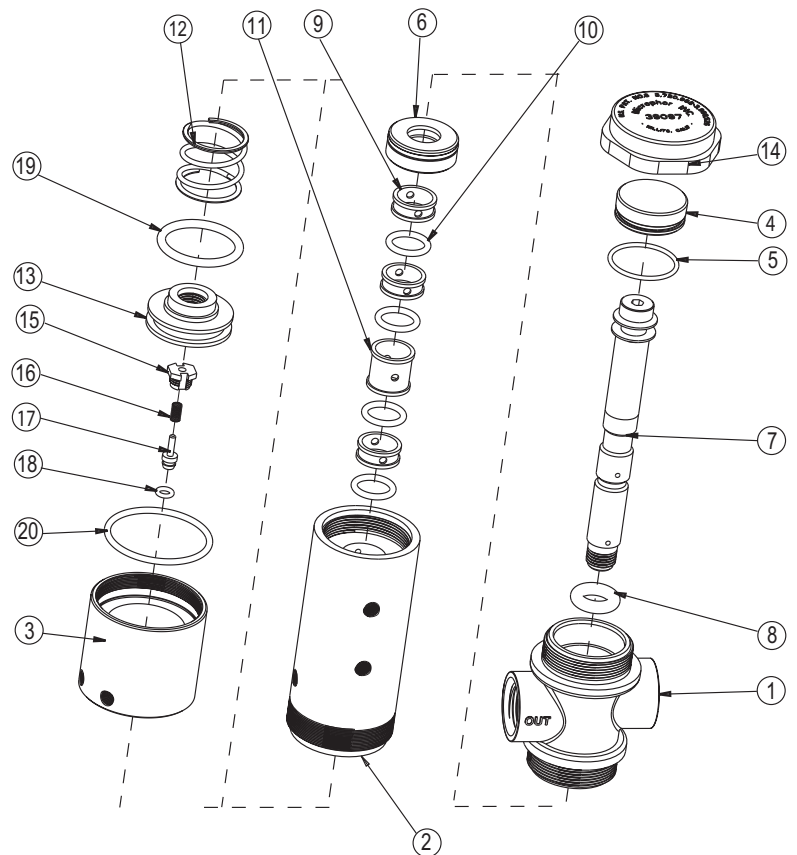

Items in **bold** are included in the Air/Water Sequence Valve Kit.

HOPPER REPLACEMENT

CAUTION: Read this entire procedure before beginning work!

1. Remove toilet from floor. Place toilet upside down on a sheet of cardboard or other padded material.
2. Remove two (2) screws from either side of hopper and lift hopper from sealing adaptor.
3. Remove o-ring between hopper and seal adaptor. Check that o-ring is not damaged, replace if necessary.
4. Re-assemble in reverse order.

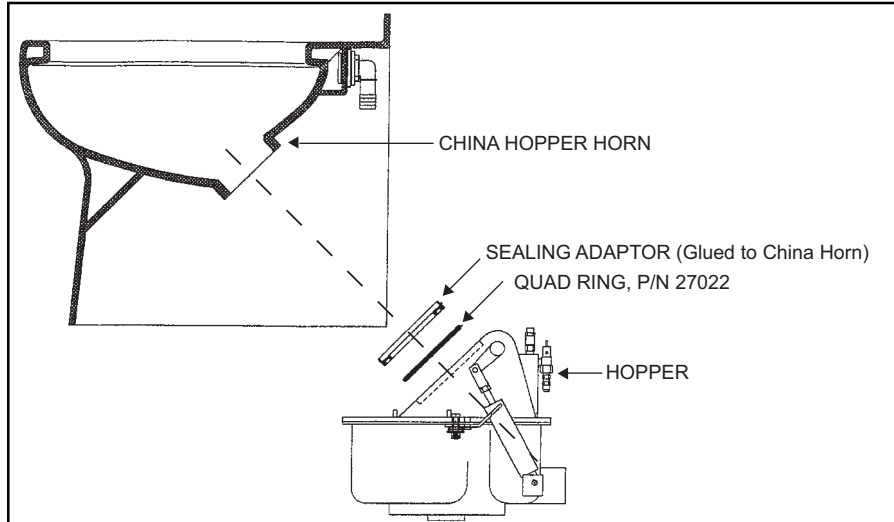

Note: The air cylinder on the hopper sub-assembly should be cleaned, lubricated and checked for adjustment whenever the toilet assembly is removed for servicing.

AIR CYLINDER ADJUSTMENT

1. Remove Hopper (see Hopper Replacement on page 9).
2. Remove the clevis pin retaining ring. Remove the clevis pin.
3. Inspect the crank arm, clevis and clevis pin for wear. Replace if required.
4. Hold the crank arm in the UP position (flapper closed).
5. Fully extend the air cylinder and note the position of the holes in the crank arm and the clevis.
The clevis hole should extend half its diameter past the crank arm hole.
6. Adjust as necessary by loosening the locknut and extend or retract the clevis as required.
7. Re-install Hopper.

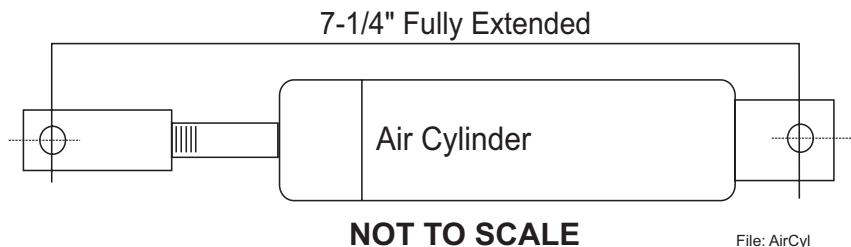

TO CHANGE FLAPPER GASKET:

1. Turn water and air off.
2. Reach behind flapper to grasp gasket tails.
3. Pull tails out of slots to remove old gasket.
4. Installation is the reverse of removal.
5. Tails must be pulled all the way through to ensure smooth surface.

AIR/WATER SEQUENCE VALVE OPERATION

1. In the normal rest position, pressurized air enters the Flush Activator and goes from Flush Activator Port 1 (Green tube) to Air/Water Sequence Valve Port 2, through Port 3 (Red tube) to Air Cylinder Port 4 holding the Flapper closed, sealing the water in the bowl and maintaining a proper water surface area.

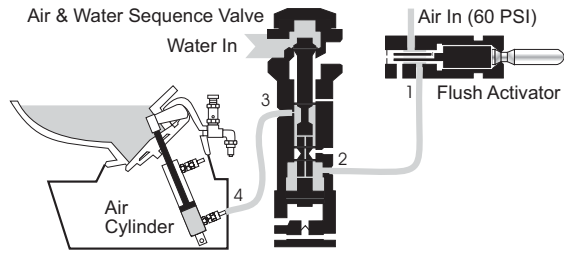

2. When the Flush Activator is pressed, air is shifted to Port 5 (Blue Tube) to A/W-Seq. Valve Port 6 and on to Air Cylinder Port 8 (White Tube). The air in the base of the Air Cylinder is bled off through Port 4 (Red Tube) to Port 3 and out Vent [1], allowing the Air Cylinder to retract, opening the Flapper. Simultaneously, pressurized air in the base of the A/W-Seq. Valve pushes the piston and spool assembly up to open the water passage, allowing water to enter and rinse the bowl. The air on the top of the piston is bled off through Port 1 and out Vent [2].

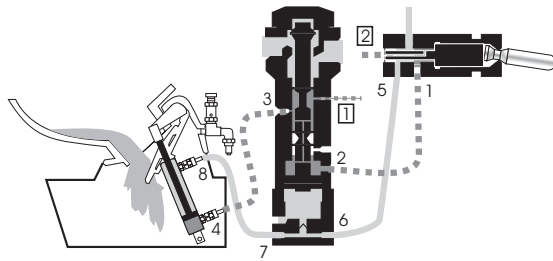

3. As the Flush Lever is released, the Flush Activator returns to the normal rest position redirecting pressurized air to Port 2, Port 3 and Port 4. The Bleed-Off Plug [12] bleeds off the air (Black Tube) under the piston, causing the spool to move downward, gradually closing the water passageway. The air having been bled off the top of the Air Cylinder Port 8 (White Tube) through the end of the Flush Activator Vent [2] (Blue Tube), allows the Air Cylinder to close the Flapper allowing water to accumulate in the bowl, restoring a proper water surface area.

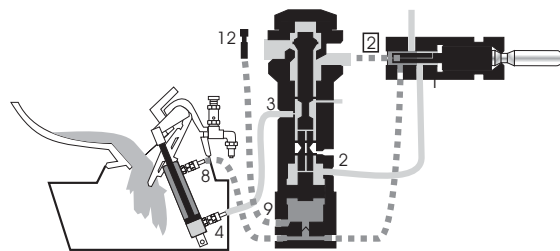

4. Near the bottom of the piston stroke, the air passageway from Port 10 (Yellow Tube) to the Hopper Port 11 is unblocked for 4-11 seconds to pressurize the hopper and expel the waste contents over the trap and into the waste line.

5. As the A/W-Seq. Spool reaches the bottom position, the water supply is shut off, completing the flush cycle.

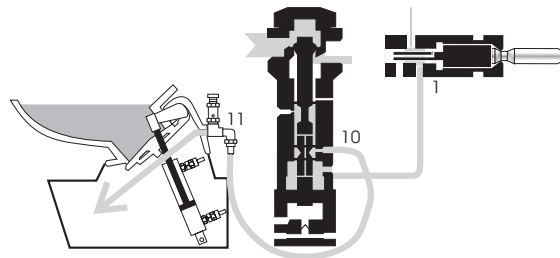

In the event of air supply failure, the spring in the Air/Water Sequence Valve maintains the valve in the closed position, blocking the water passageway. The flapper will open and allow water in the bowl to flow into the hopper forming a water seal.

BASIC TOILET OPERATION

File: AWS-bw

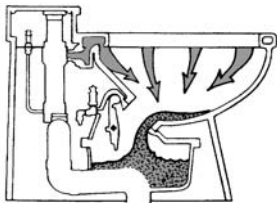

When the flush activator is pressed the flapper opens, allowing wastewater to flow into the hopper. Clean water enters the bowl from the rim to thoroughly wash the bowl.

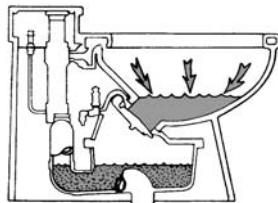

After 4-8 seconds, the flapper closes. Clean water continues to flow into the bowl where it remains until the next flush.

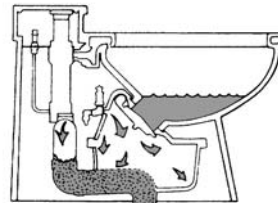

When the flapper has closed, compressed air enters the hopper, pushing the waste over the trap and into the wasteline.

File: 210-op

Downward Discharge

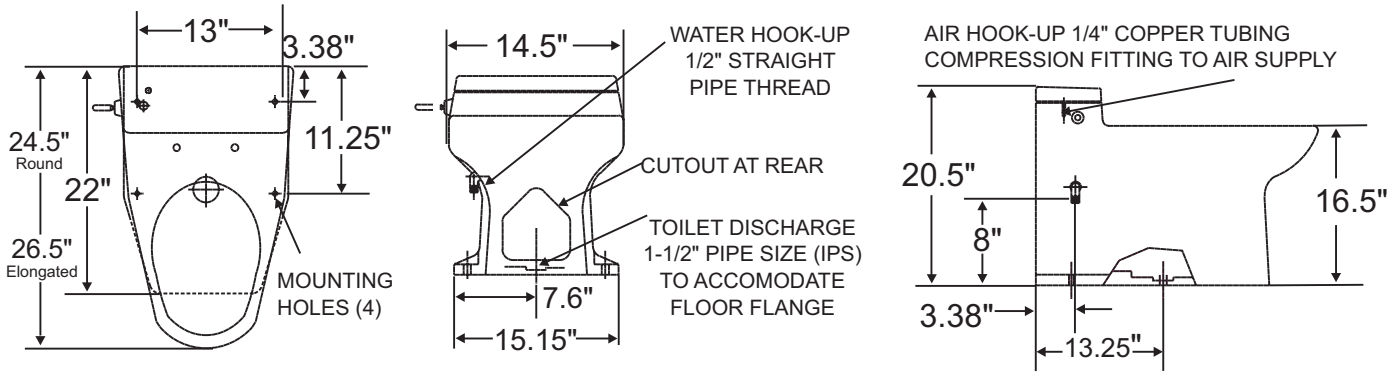

Rear Discharge

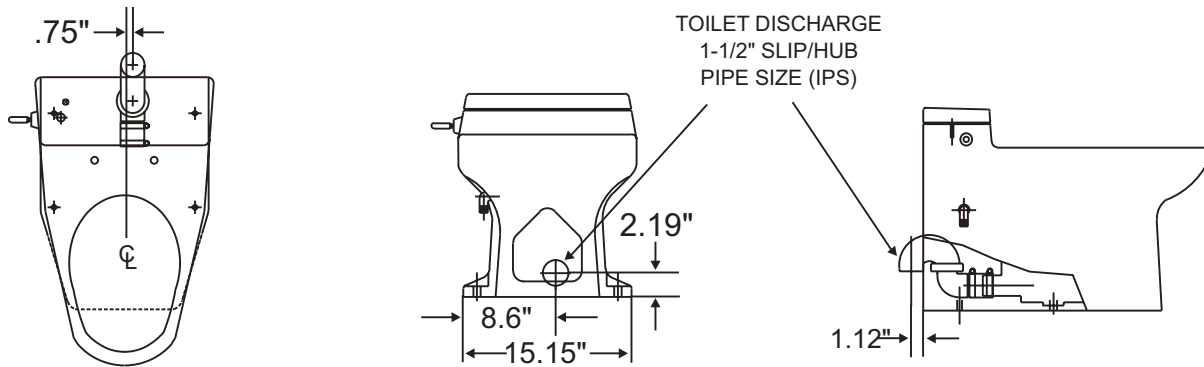

Remote Flush Rough-In

FLUSH ACTIVATOR

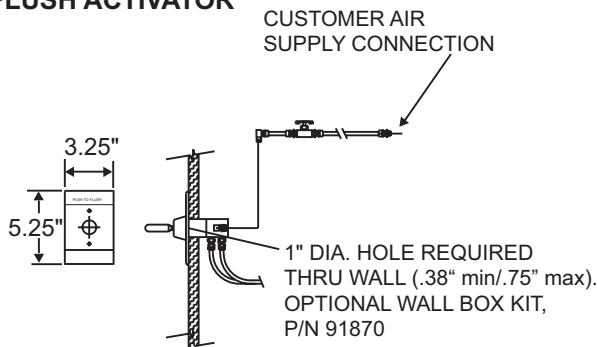

VALVE ASSEMBLY

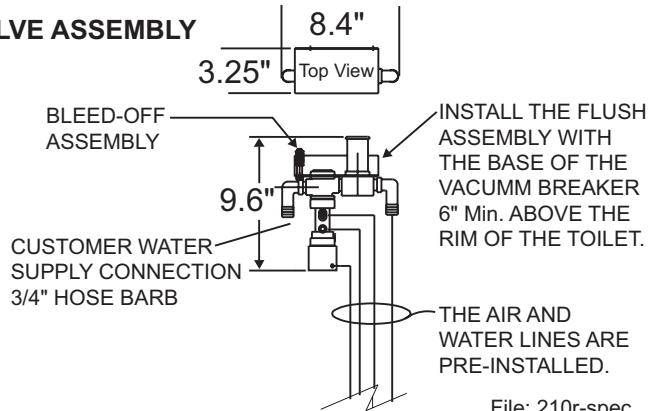

File: 210r-spec

THE MAXIMUM WATER LINE DISTANCE BETWEEN THE TOILET AND THE REMOTE FLUSH ASSY IS SIX (6) FEET.

LF-219 ROUGH-IN DIMENSIONS

NOTE: All dimensions may vary 1/2"

NOTE: Do NOT use P-Trap in vertical rise waste line applications.

Downward Discharge

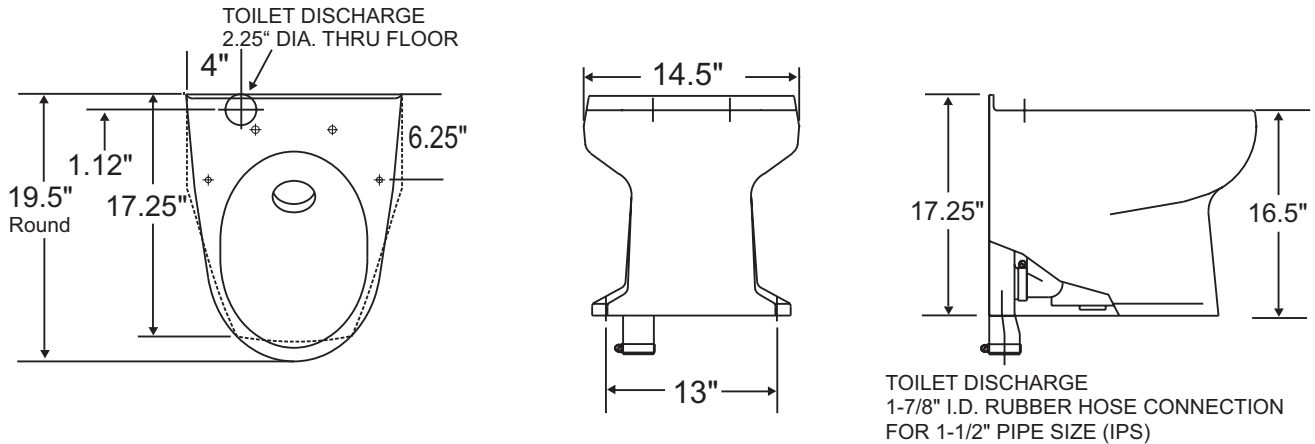

Rear Discharge

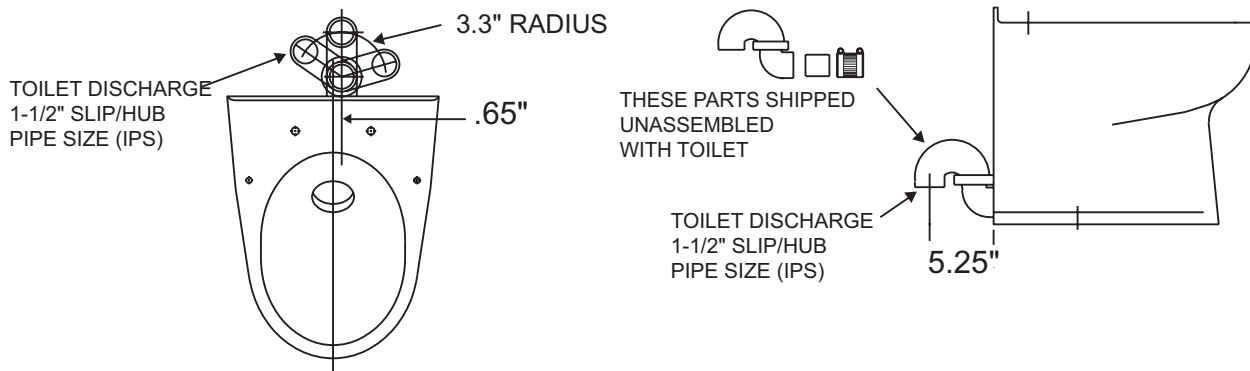

Integral Flush

Integral Check Valve - No Vacuum Breaker - Check Local Code for Approval.

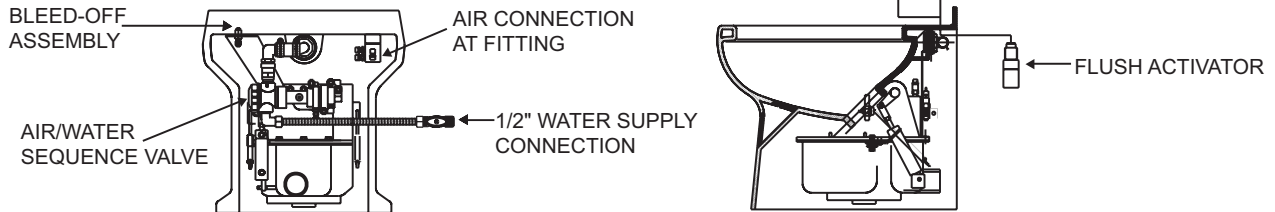

Remote Flush Rough-In

FLUSH ACTIVATOR

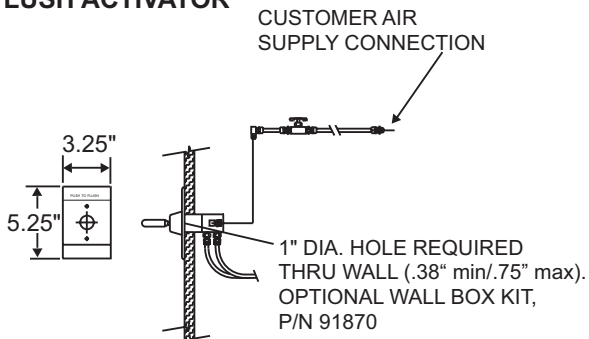

VALVE ASSEMBLY

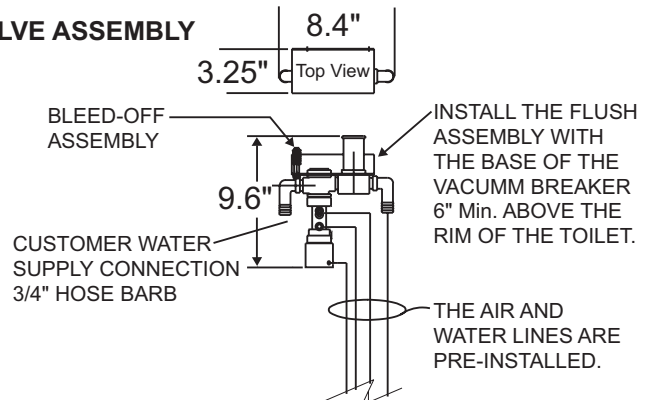

THE MAXIMUM WATER LINE DISTANCE BETWEEN THE TOILET AND THE REMOTE FLUSH ASSY IS SIX (6) FEET.

File: 219-Spec

General Terms and Conditions Covering Sales

All sales of merchandise by Microphor are subject to the General Terms and Conditions as provided herein and on invoices issued by Microphor.

PRICES: All goods and products sold by Microphor will be billed to its customers according to the price lists contained in the current bulletins and price lists issued by Microphor. All prices are subject to change without notice and supersede all prior price lists. Microphor assumes no obligation to sell to anyone at any price or at any of the terms listed herein.

TERMS: Customer orders will be accepted subject to credit investigation, and approval, and delivery may be withheld on accepted orders, other than cash in advance, without any liability on the part of Microphor if, in its opinion, there is doubt concerning the ability of the customer to pay for merchandise ordered under the terms and conditions contained in current bulletins and price lists issued by Microphor. After delivery of merchandise, should Microphor, at its sole discretion, institute legal action for collection, customer agrees to pay all attorney fees and costs incurred by Microphor by reason of such action.

FREIGHT AND DELIVERY: PRICES ARE F.O.B. FACTORY: Delivery to the initial carrier shall constitute delivery to the customer. Microphor's responsibility ceases upon delivery in good order to the carrier and all goods are shipped at the customer's risk. Customer shall be responsible for filing a claim with carrier. Microphor shall not be liable for any delay or failure in the delivery or shipment of merchandise against an accepted order or for any damages suffered by reason thereof when such a delay or failure is, directly or indirectly, due to accident (in manufacture or otherwise) fire, flood, riot, war, embargo, labor stoppage, delays in transportation, inadequate transportation, shortage of materials or supplies, regulation by Government authority or any like or dissimilar cause or causes beyond the control of Microphor. Shipping weights and freight estimates given are approximate, for customer's convenience only, and are not guaranteed.

SHORTAGES OR VARIANCES: No claims for variances from or shortages in orders will be honored unless presented within fifteen (15) days after customer's receipt of order.

CANCELLATION OF ORDERS: After a purchase order has been provided by customer, written or oral, an order may be modified canceled only upon written confirmation by Microphor. Additional costs incurred by Microphor as the result of modification or cancellation will be billed to customer. Orders for merchandise requiring special manufacturing or supervision, or articles of a special nature, will not be canceled after production is commenced.

TAXES: Taxes, whether local, state or U.S. government now in effect, or hereafter levied, upon the product, sale thereof, use, shipment, or otherwise, of goods ordered or sold shall be charged to and paid by customer.

CHANGES IN DESIGN: Factors beyond the control of Microphor, the need for continuing improvement of product for competitive reasons, or for any other reason, may require changes from time to time in products and their packaging. Microphor reserves the right to make such changes of any kind, at any time, without notice. Microphor may also, from time to time discontinue the sale of its products, without notice.

LIMITED WARRANTY: Microphor warrants its products to be free from significant defects in material and workmanship under normal use and service for a period of two (2) years from the date of purchase, by the original purchaser. THE OBLIGATIONS OF MICROPHOR UNDER THIS WARRANTY are limited to the repair or replacement, at Microphor's option, of defective parts of the product which shall, within two (2) years from the date of purchase, (Note: certain air compressors and their parts, oily water separators and their parts are warranted for one (1) year from date of purchase.) be returned with proof of purchase to Microphor's factory, Willits, CA, TRANSPORTATION CHARGES PREPAID. When it is impractical to return the defective parts of such products to Microphor's factory, then Microphor shall be liable solely for supplying the material necessary to replace or repair the defective parts. WHILE MICROPHOR WILL NOT CHARGE FOR LABOR IN CONNECTION WITH WARRANTY REPAIRS OR REPLACEMENTS MADE AT ITS FACTORY, MICROPHOR AT ITS SOLE DISCRETION MAY CHARGE FOR LABOR AND EXPENSE INCURRED BY IT IN CONNECTION WITH WARRANTY REPAIRS MADE AT THE CUSTOMER'S PLANT OR LOCATION. In any event, Microphor reserves the right to determine whether or not a defect exists for which it is responsible under this warranty. A returned material authorization must be obtained from Microphor Customer Service prior to the return of any merchandise. This warranty is void if the product has been damaged by customer prior to acceptance or as a result of unreasonable use, neglect, alteration, improper service, improper installation or other causes not arising out of defects in material or workmanship or if any serial number on the product has been altered or defaced.

MICROPHOR SHALL NOT BE RESPONSIBLE FOR LOSS OF USE OF PRODUCT OR OTHER INCIDENTAL, SPECIAL OR CONSEQUENTIAL DAMAGES INCURRED BY PURCHASER INCLUDING BUT NOT LIMITED TO PERSONAL INJURY AND PROPERTY DAMAGE.

This warranty is in lieu of all other warranties express or implied, including without limitation, any implied warranties of merchantability or fitness for a particular purpose, and Microphor neither assumes nor authorizes any representative or any other persons to assume for it any other liability in connection with the sale of its products. Microphor makes no warranties, express or implied, with respect to parts, accessories, components or other goods not manufactured by Microphor.

CONTRACT WITH CUSTOMER: No terms and conditions of a customer's order at variance with Microphor's General Terms and Conditions and/or its invoice shall be binding upon Microphor unless specifically agreed to by Microphor in writing. In acknowledging any order, any and all terms and/or conditions of customer's order or correspondence contrary to those of Microphor are to be deemed waived by customer.

PATENTED PRODUCTS: Certain of Microphor's products and processes are patented (or patents are pending) under U.S. and foreign patents. Manufacture, reproduction or practice of such products, or processes without prior written authorization from Microphor may result in liability for patent infringement.