

HeadMaster Marine Toilet Owner's Manual



HeadMaster

Table of contents

- | | |
|-------------------------------|----------------------------------|
| 1 Using this guide | 7 Wiring Schematics |
| 2 General safety instructions | 8 Maintenance & Winterising |
| 3 Intended Use | 9 Troubleshooting |
| 4 Components | 10 Warranty & Customer Service |
| 5 Specifications | 11 Exploded Drawing & Parts List |
| 6 Operation | 12 Customer Service |

1) Notes on using the manual



Failure to observe this Safety Instruction can cause material damage and impair the function of the device.

2) General safety instructions

The manufacturer will not be held liable for claims for damage resulting from the following:

- Faulty assembly or connection
- Damage to the unit from mechanical influences, misuse or abuse
- Alterations to the unit without express written permission from the manufacturer
- Use for purposes other than those described in the operating manual

The following statements must be read and understood before installing, servicing and/or operating this product on a boat.

Modification of this product may result in property damage.

Lee Sanitation recommends that a qualified marine technician or electrician install or service this product. Equipment damage, injury to personnel or death could result from improper installation.

LEE SANITATION ACCEPTS NO RESPONSIBILITY OR LIABILITY FOR DAMAGE TO EQUIPMENT, OR INJURY OR DEATH TO PERSONNEL THAT MAY RESULT FROM IMPROPER INSTALLATION, SERVICE OR OPERATION OF THIS PRODUCT.



Hazard of Flooding

If the toilet is connected to ANY through-the-hull fittings, ALWAYS close sea-cocks when toilet is not in use (even if boat is unattended for a brief period). All passengers MUST be instructed on how to close valves when the toilet is not in use. Failure to do so can result in flooding which can cause loss of property and life.

If the toilet uses fresh water for flushing and is connected directly or indirectly to a shore side water authority mains system at ANY time, shore side water connections MUST be disconnected if the boat is unattended (even if boat is unattended for a brief period). Failure to do so can result in flooding which can cause loss of property and life.

Before beginning any work on this product, be sure that all electrical power to the unit has been turned off and that sea-cocks are in the CLOSED or OFF position. Failure to do so can result in flooding which can cause loss of property and life.

Overfilling the holding tank can create serious damage to the sanitation system, such as rupturing the holding tank and releasing tank contents into the bilge.

To prevent this possibility, Lee Sanitation recommends using a suitable tank level indicator.

3) Intended Use

The LeeSan HeadMaster Macerator toilet provides an electric-flush toilet that macerates waste and pumps it to a holding tank or other effluent storage / disposal system. Operated by a wall mounted flush switch, the toilet allows the user to add water to the bowl (before or after flushing) and to flush the toilet by pushing a button.

4) Contents & Components

- A Macerator toilet
- B Flush switch
- C Electrical input wire
- D Output wires (2) to toilet
- E Input wires (2) from flush switch
- F Output wires (2) to ground connection
- G Floor mounting hardware kit

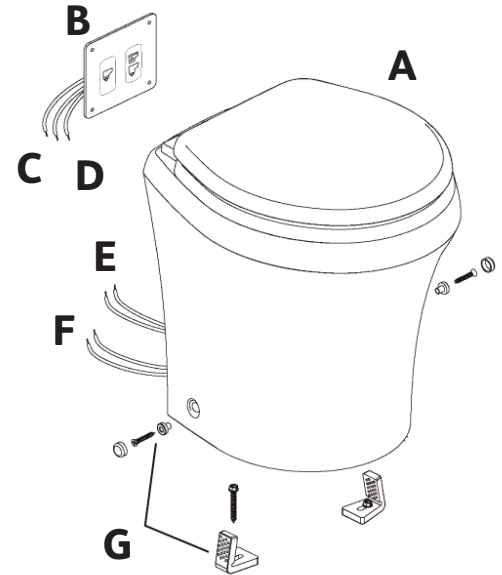

- 1 Check valve
- 2 Discharge loop outlet
- 3 Discharge adapter fitting
- 4 Discharge hose fitting
- 5 Macerator pump
- 6 Water valve
- 7 Water valve fitting – 1/2"

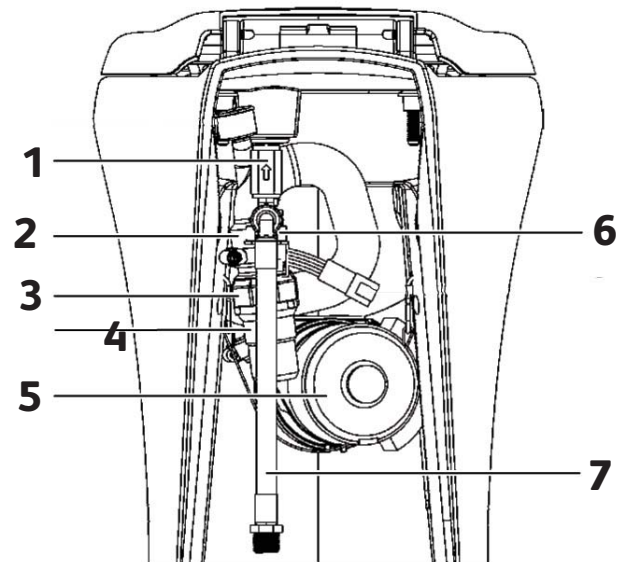

5) Specification

- Toilet: vitreous ceramic
- Macerator pump body: glass-filled polypropylene
- Flush switch panel: powder-coated aluminum
- Circuit breaker 25 amps @ 12v DC; 15 amps @ 24v DC
- Input Fitting ½" (13 mm) ID flexible water line
- Input Flow rate 2.5 gallons per minute / 9.5 litres per minute
- Discharge Hose Inside diameter 1 ½" (38 mm)

Dimensions:

A 851mm (33½")
 B 457mm (18")
 C 406mm (16")
 D 375mm (14¾")
 E 502mm (19¾")
 F 432mm (17")

G 775mm (30½")
 H 381mm (15")
 I 391mm (15½")
 J 375mm (14¾")
 K 502mm (19¾")
 L 356mm (14")

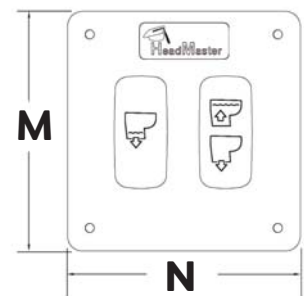

M 85mm (3¼")
 N 75mm (3")

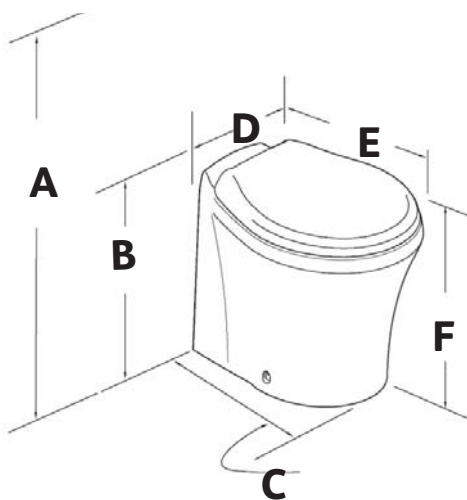

Standard Height

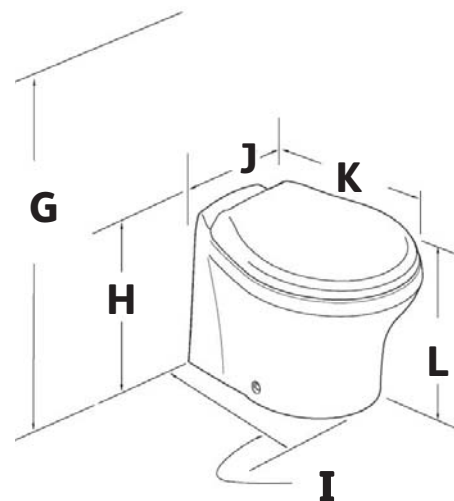

Low Height

6) Operation

ADDING WATER TO TOILET BOWL

Press “Add Water” switch **1** and hold until desired water level is achieved. (Do not press “Add Water” switch too long or overflow may occur). More water is usually added only when flushing solids.

FLUSHING THE TOILET

Press “Flush” switch **2** down and hold for a few seconds after waste drains from toilet bowl (about five seconds). This switch activates the macerator pump that siphons water and waste from the bowl, macerates, and propels the effluent through the discharge hose.

To use less water for liquid-only flushes, press “Flush” switch for shorter period of time.

“DRY BOWL” OPERATION

During periods of travel at sea, water in a toilet bowl can splash out and into the toilet area. To avoid this press the “Dry Bowl” switch **3** to drain water completely from toilet bowl. Water is not added to bowl during or after pressing the “Dry Bowl” switch.



Do Not Flush Waste with “Dry Bowl” Switch!



To maintain proper cleanliness and operation of the toilet and macerator pump, water should be used with every flush.

Do Not Flush Foreign Objects! Flush only water, bodily wastes and rapid-dissolving toilet tissue.

Do not flush wet wipes, sanitary napkins, condoms, nappies, paper cups, cotton swabs, food, hair or liquids such as oils or solvents as clogging or damage to the toilet or toilet system may occur.

Make sure that guests understand toilet operation before use.

7) Wiring Schematic

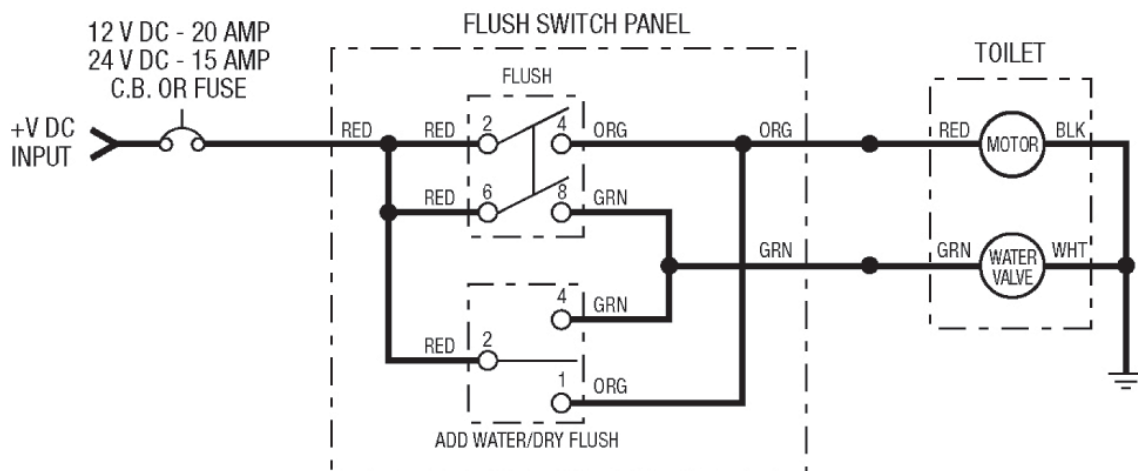

8) Maintenance and winterising

CLEANING THE TOILET

To maintain the toilet's original, lustrous appearance, use SeaLand® Toilet Bowl Cleaner



To avoid damaging internal seals, do not clean toilet with abrasive cleaners, caustic chemicals, or lubricants and cleaners that contain alcohols or petroleum distillates.

ROUTINE MAINTENANCE

Monthly - Inspect toilet, plumbing, and plumbing connections, wires, and wire connections. Open and close all plumbing valves, including seacocks. Check in-line water filters and vented loops for blockage.

Annually - Check water valve filter. Also check water valve filter if water flow into toilet becomes insufficient.

DURING EXTENDED PERIODS OF NON-USE

The macerator toilet and sanitation hoses should be protected if toilet will not be needed for an extended period of time (more than two weeks, especially in hot weather).

1. Flush toilet in “Normal” mode Note: If using sea water for flushing, shut off power to sea water pump and add fresh water by pouring directly into the bowl during the flush cycle.
2. Flush toilet at least five times.
3. Turn off water supply to toilet.
4. Flush the toilet without water. Repeat three times. (This procedure will minimize any remaining water in the macerator pump.)
5. Turn off power to the toilet.

If system will be subjected to freezing temperatures, please follow above procedure then winterise system as described below.

WINTERISING

At the end of each season, the HeadMaster Macerator toilet should be winterised for storage by using potable water-safe antifreeze LEEFREEZE (if boat or vehicle will be exposed to freezing temperatures).



**Use nontoxic antifreeze designated for potable water systems.
Never use automotive-type antifreeze in freshwater systems.**

1. Empty the holding tank.
2. Pour antifreeze mixture into the bowl and flush through the toilet and into entire system, including the waste holding tank, diverter valve connections, discharge pumps, etc.
3. Turn off power to toilet.

9) Troubleshooting

Symptom	Possible Cause	Corrective Action
Flush function works, but water in bowl empties slowly or not at all.	Discharge piping is pinched or kinked. Discharge piping is too high. (Remember, all upward vertical loops should not exceed a total of 9.8 feet (3 m) in height.) The macerator pump or discharge piping is blocked	Check discharge piping. Reroute discharge piping. Close seacocks and clear blockage.
Macerator pump makes unusually loud noise or continually trips breaker.	Foreign material in pump chamber.	Close seacocks and clear foreign material.
Flush cycle is not activated after pushing on flush switch.	Electrical power to toilet is shut off or disrupted. Flush switch is malfunctioning.	Check wiring and circuit breakers (or fuses). Replace flush switch.
Insufficient or no water enters the bowl.	Water supply line is pinched or kinked. Screen in water valve is blocked. Intake water filters are blocked (in raw water system). Water valve is malfunctioning.	Check water supply line. Clear blockage at water valve. Clear water filters. Replace water valve.

10) Warranty & Customer Service

Warranty arrangements are in accordance with EC Directive 44/1999/CE and the normal conditions applicable for the country concerned. For warranty or other service, please contact Lee Sanitation Ltd.

Any damage due to improper use is not covered by the warranty.

The warranty does not cover any modifications to the product or the use of non-original parts; the warranty does not apply if the installation and operating instructions are not adhered to and no liability shall be entertained.

Product liability of Lee Sanitation Ltd and its subsidiary companies does not include damages which may arise from: faulty operation; improper alterations or intervention in the equipment; adverse effects from the environment which may impact the equipment itself or the direct vicinity of the equipment or persons in the area.

11) Exploded Drawing & Parts List

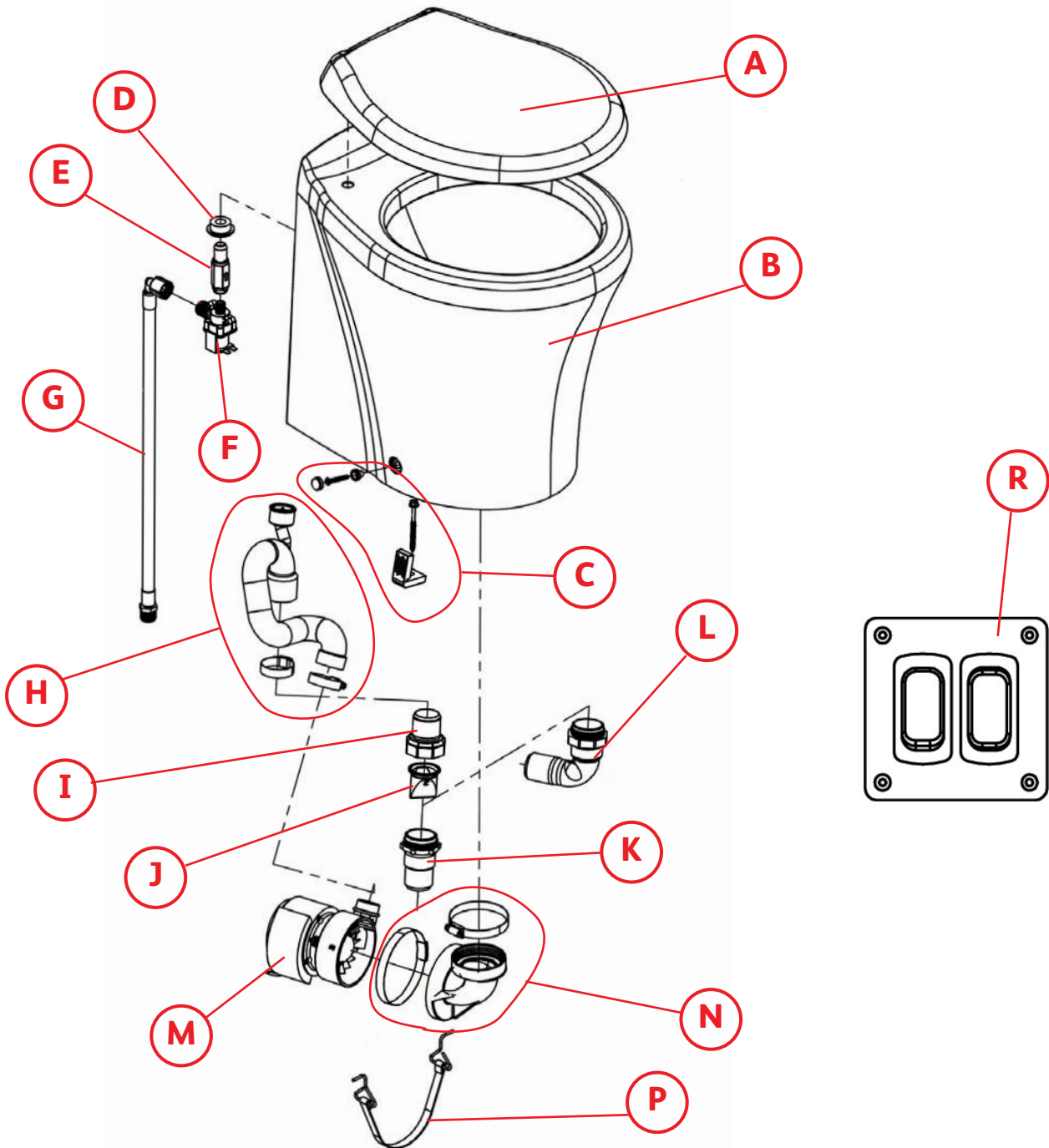

Item	Description	Part No:	Item	Description	Part No:
A	Toilet Seat and Lid	03140	I	Discharge Adapter	03154
B	Porcelain Bowl	03520	J	Outlet Duckbill Valve 1 1/2"	03019
C	Toilet Fixing Kit	03142	K	Outlet Hose Straight Nipple	03058
D	Seal Grommet 1/2"	03151	L	Outlet Hose Elbow Nipple	03522
E	Check Valve	03150	M	Macerator Motor Assembly, 12v	03156
F	Water Valve Kit, 12v	03521		Macerator Motor Assembly, 24v	03157
	Water Valve Kit, 24v	03524	N	Bowl Outlet Eblow	03163
G	Water Input Supply Hose	03144	P	Motor / Pump Mounting Strap	03147
H	Pump Discharge Pipe	03430	R	HeadMaster Switch Panel 12/24v	09005

11) Customer Service

There is a strong, worldwide network to assist in servicing and maintaining your sanitation system.

Please call for your nearest dealer / service representative.

Lee Sanitation Ltd.

Wharf Road

Fenny Compton

Warwickshire, England

CV47 2FE

T: +44(0)1295 770000

F: +44(0)1295 770022

E: sales@leesan.com W: www.leesan.com

Related Toilet Products from Leesan

Toilet Bowl Cleaner
Part No: 000016



Single Ply Loo Roll (Pack of 4)
Part No: 000404



LeeScale ~ Descaler
Part No: LEESCALE



Self Pump Out Kit
Part No: 01019



LeeFreeze
Part No: LEEFREEZE5



Clean & Green
(12 Sachets)
Part No: 512602

More products to be found at www.leesan.com