

- Stainless Steel Pump housing manufactured in brushed or 3D statically mounted pump unit
- Provide weather protection and are constructed in heavy duty vandal resistant stainless steel
- Lockable against unauthorised access, without causing restriction for service
- Hydraulic operation, security door with safety pressure release or shuttler
- Choise of control panels, coin, card or token operation
- Front panel easily removable for major maintainance
- Saugschlauchlänge 15m
- motor driven hose recoil unit

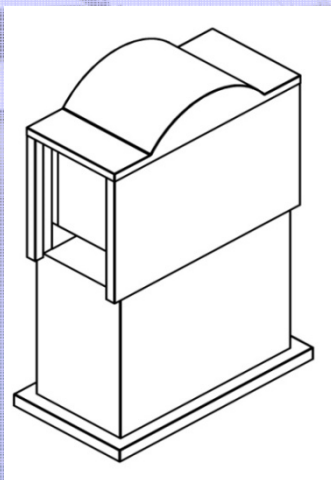

Pump-out Station LS1000W



Dimension:

Length	=	1360mm
Wide	=	750mm
Height	=	2050mm

Data:

Volume	:	250l/min
Motor	:	400V/3,6 kW
Weight	:	250kg
Suction max	:	9m
Delivery max:	:	180m
Delivery head:	:	20m
Connection:	:	2" IG

Lee Sanitation Ltd
Wharf Road, Fenny Compton, CV47 2FE
0044 (0)1295 770000