

## Sanimarin SN31 Comfort

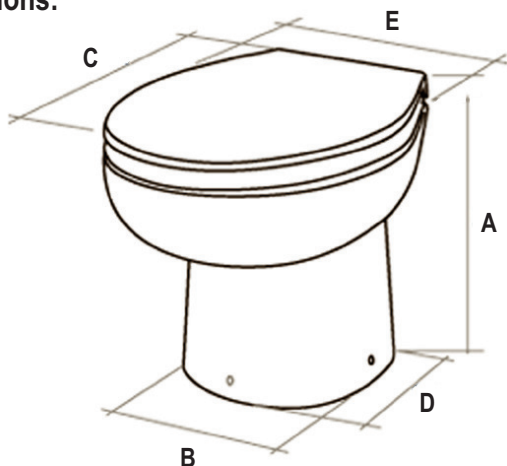

Part No: 03825 ~ 12v, 03826 ~ 24v

### Dimensions:



<b>A</b>	<b>350mm (13<sup>3</sup>/<sub>4</sub>"</b> )	<b>D</b>	<b>240mm (9<sup>1</sup>/<sub>2</sub>"</b> )
<b>B</b>	<b>250mm (10"</b> )	<b>E</b>	<b>370mm (14<sup>1</sup>/<sub>2</sub>"</b> )
<b>C</b>	<b>420mm (16<sup>1</sup>/<sub>2</sub>"</b> )		

## SANI MARIN

### PUMPED ELECTRIC, MACERATOR TOILET

Quiet and effective.

Discharge is through conventional 1" - 1½" hose. Will discharge to a higher head than most other toilets.

- Operated by a two-position switch:  
 Add water: bowl flush command  
 Pump out: macerate and empty command
- Minimal Routine Maintenance
- Easy to Clean
- 2 Year Guarantee

No other macerator pump achieves the Sanimarin Comfort performance while operating in virtual silence.

The result is a "Comfortable" on-board facility at a very reasonable cost.

### NOTE:

Salt water flush requires an additional, raw water pressure pump.

### TECHNICAL SPECIFICATIONS:

<b>Water Consumption</b>	<b>1.2 to 2.2L</b>
<b>Water Pressure</b>	<b>20 - 45 PSI</b>
<b>Water Connection</b>	<b>¾" BSP</b>
<b>Waste Outlet</b>	<b>1" or 1½" (25 to 38mm)</b>
<b>Electric Consumption:</b>	<b>12 Volt      21 Amps</b>
	<b>24 Volt      11 Amps</b>
<b>Start-up-surge:</b>	<b>12 Volt      133 Amps</b>
	<b>24 Volt      69 Amps</b>
	<b>12 Volt Motor 260 Watts</b>
	<b>24 Volt Motor 260 Watts</b>
<b>Weight:</b>	<b>18 Kg</b>

## Sanimarin SN31 Comfort Plus



Part No: 03827 ~ 12v, 03828 ~ 24v

### Dimensions:

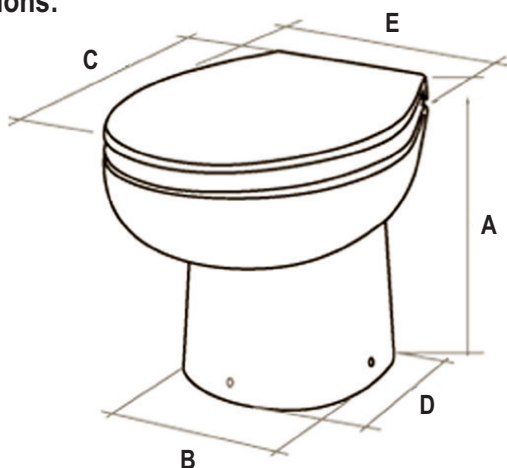

<b>A</b>	<b>350mm (13<sup>3</sup>/<sub>4</sub>"</b> )	<b>D</b>	<b>240mm (9<sup>1</sup>/<sub>2</sub>"</b> )
<b>B</b>	<b>250mm (10"</b> )	<b>E</b>	<b>370mm (14<sup>1</sup>/<sub>2</sub>"</b> )
<b>C</b>	<b>420mm (16<sup>1</sup>/<sub>2</sub>"</b> )		

## SANI MARIN

### PUMPED ELECTRIC, MACERATOR TOILET with SINGLE BUTTON OPERATION

The Flush Button triggers an automatic flush - discharge - refill cycle.

The cycle is controlled via an electronic box.

It lasts 19 sec and consumes 2.2 l of water.

Quiet and effective.

Discharge is through conventional 1" - 1<sup>1</sup>/<sub>2</sub>" hose. Will discharge to a higher head than most other toilets.

- Operated by a SINGLE switch:
- Minimal Routine Maintenance
- Easy to Clean
- 2 Year Guarantee

No other macerator pump achieves the Sanimarin Comfort Plus performance while operating in virtual silence.

The result is a "Comfortable" on-board facility at a very reasonable cost.

#### NOTE:

Salt water flush requires an additional, raw water pressure pump.

#### TECHNICAL SPECIFICATIONS:

<b>Water Consumption</b>	<b>2.2L</b>
<b>Water Pressure</b>	<b>20 - 45 PSI</b>
<b>Water Connection</b>	<b>3/4" BSP</b>
<b>Waste Outlet</b>	<b>1" or 1 1/2" (25 to 38mm)</b>
<b>Electric Consumption:</b>	<b>12 Volt      21 Amps</b>
	<b>24 Volt      11 Amps</b>
<b>Start-up-surge:</b>	<b>12 Volt      133 Amps</b>
	<b>24 Volt      69 Amps</b>
	<b>12 Volt Motor    260 Watts</b>
	<b>24 Volt Motor    260 Watts</b>
<b>Weight:</b>	<b>18 Kg</b>